



Technical specifications :

- Compact and portable size
- Continuous variable speed control
- On/Off foot switch
- One-touch change of the driving direction for efficient operation
- No noise, vibration or heat after a long time of operation, ensuring smooth operation
- Can be delivered at your choice with a laboratory straight handpiece (**SDE-H37L**) or with a E-type motor (**SDE-M33E**)
- Straight handpiece or Contra-angle can be combined with E type Motor

Note : the contra-angle is not provided here

Control Unit :

VOLTAGE	CYCLE	AMP	RPM	WEIGHT (kg)	DIMENSIONS (mm)		
					W	D	H
110~220V	50/60Hz	DC 30V / 0.5 A	Handpiece Max	1.5 (kg)	100	130	67

Motor Handpiece :

MODEL	NON LOAD R.P.M	MAX TORQUE (gf · Cm)	ELECTRIC POWER (W)	WEIGHT (g)	DIMENSIONS (mm)				
					L	L1	L2	D1	D
SDE-M33E	33,000	240	35	142	115	30.5	84	10	25.8
SDE-H37L	35,000	280	50	208	152	75	82	18	29.5

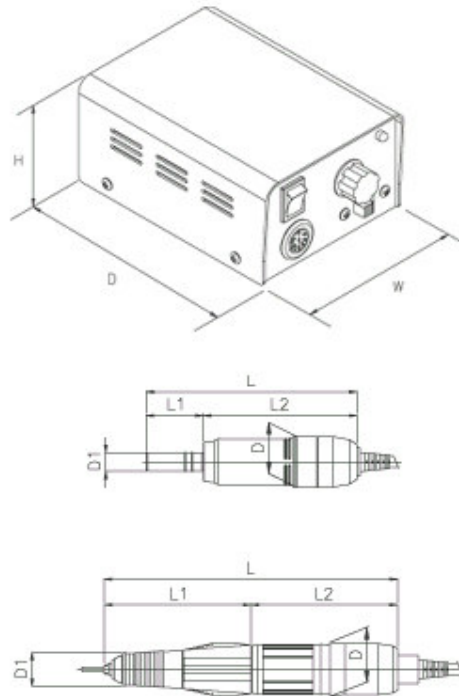

Head Office
Rue des Tondeurs 11
9570 WILTZ
Luxembourg

Postal Address
B.P. 6
9501 WILTZ
LUXEMBOURG

Tel : +339 54 55 76 76
Fax : +352 26 95 07 71
Mail : info@maecolux.com
Web : www.maecolux.com